

# GLASS DOOR MERCHANDISER FREEZERS

MODEL:  MXM3-72FHC  MXM3-72FBHC



MXM3-72FHC



MXM3-72FBHC

Maxx Cold Glass Door Merchandisers are designed for durability and visual appeal to display your product. The glass door merchandisers are energy efficient and effective at displaying product at the right temperature to preserve freshness and prolong shelf life. Simple-to-use, programmable solid-state digital controls deliver accurate temperature regulation.

## FEATURES AND CONSTRUCTION

- Constructed of a powder coated steel exterior and powder coated aluminum interior
- Triple pane, heated, insulated self-closing glass doors
- Interior LED lighting
- Bottom mounted compressor
- Twelve (12) adjustable heavy-duty PE-coated wire shelves
- Six (6) rollers (3 with leveling feet)
- Digital controls with LED temperature display
- Automatic defrost system
- Provided with lock and key set for security
- Illuminated top panel for advertising/promoting products
- Equipped with integrated condensate evaporator therefore no drain line connection is needed

## ELECTRIC

230V / 60Hz / 1Ph  
6' (2m) NEMA L14-20 cord set included



NEMA L14-20

## 3RD PARTY APPROVALS



Intertek

Certified to ANSI NSF 7



Intertek

Certified to ANSI UL 471



Zero Ozone Depletion Potential

## MAXX COLD WARRANTY (USA / CANADA)

Contact Maxx Cold for warranty statement at  
TechnicalServices@TheLegacyCompanies.com or 877.368.2797

## NOMINAL STORAGE CAPACITY

MXM3-72FHC/72FBHC..... 72 Cu Ft (2039 L)

## TEMPERATURE

Holding temperature ..... 0°F to 10°F (-18°C to -12°C)

- Oversized refrigeration system delivers optimum storage temperature and rapid temperature recovery

MXM3-72FHC / MXM3-72FBHC

FRONT VIEW

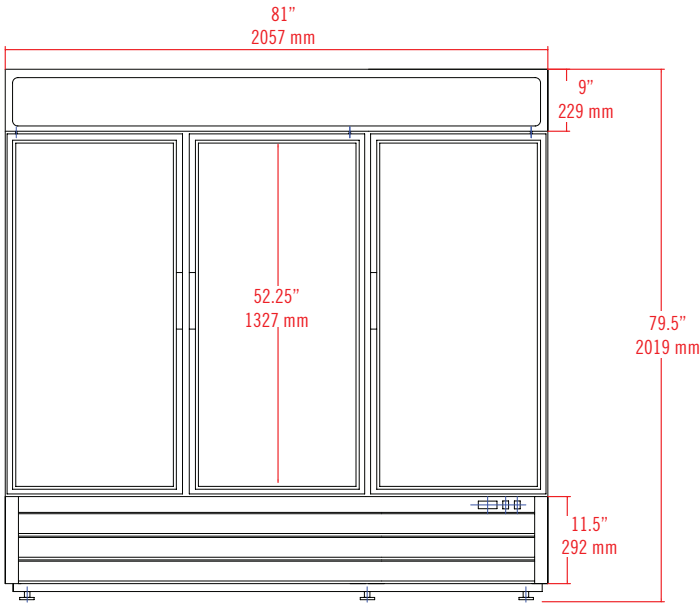

TOP VIEW

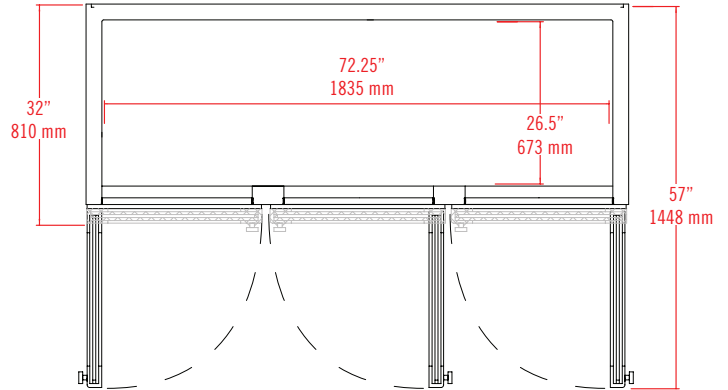

BACKLIT DISPLAY PANEL

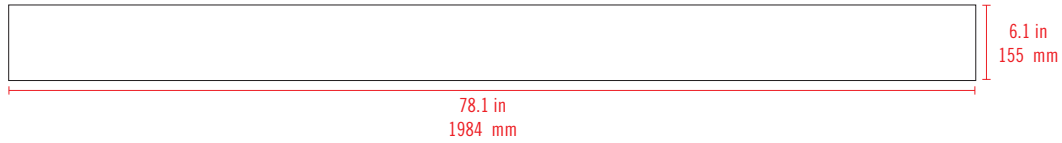

MODEL	EXTERNAL DIMENSIONS	INTERNAL DIMENSIONS	NOMINAL CAPACITY	HOLDING TEMPERATURE RANGE	AMP DRAW	SHIPPING WEIGHT	REFRIGERANT AND CHARGE SIZE	DOORS / SHELVES	ELECTRICAL
MXM3-72FHC	81" x 32" x 79.5" (2057 x 810 x 2019 mm)	72.25" x 26.5" x 52.25" (1835 x 673 x 1327 mm)	72 Cu Ft (2039 L)	0°F to 10°F (-18°C to -12°C)	9.0A	670 lbs (305 kg)	R-290A 5.29 oz (150 g)	3 / 12	115V / 60Hz / 1Ph
MXM3-72FBHC	81" x 32" x 79.5" (2057 x 810 x 2019 mm)	72.25" x 26.5" x 52.25" (1835 x 673 x 1327 mm)	72 Cu Ft (2039 L)	0°F to 10°F (-18°C to -12°C)	9.0A	670 lbs (305 kg)	R-290A 5.29 oz (150 g)	3 / 12	115V / 60Hz / 1Ph

### INSTALLATION

- Units are equipped with roller wheels and leveling feet. Swivel caster wheels are an available option for increased mobility.